

REVISIONS				
ZONE	REV.	DESCRIPTION	DATE	APPROVED
	B	.5 TO .530 (2 PLCS), .43 TO .438, .156 OBR TO .187	5-9-05	

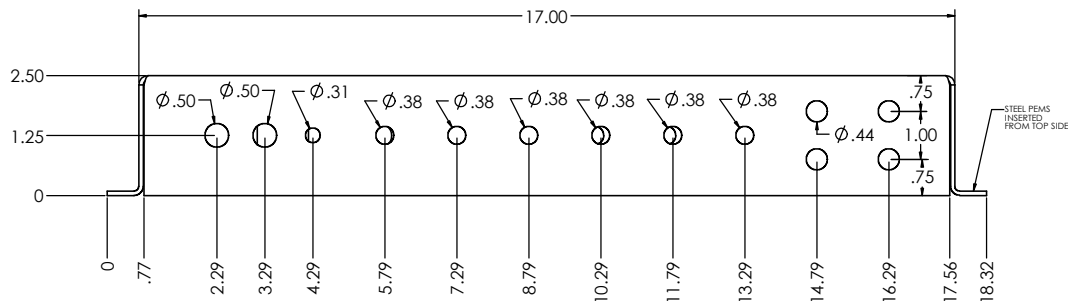
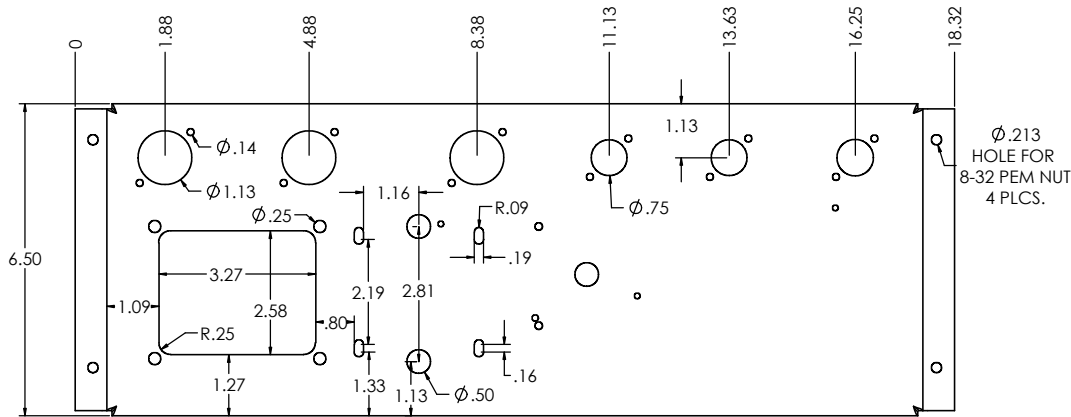
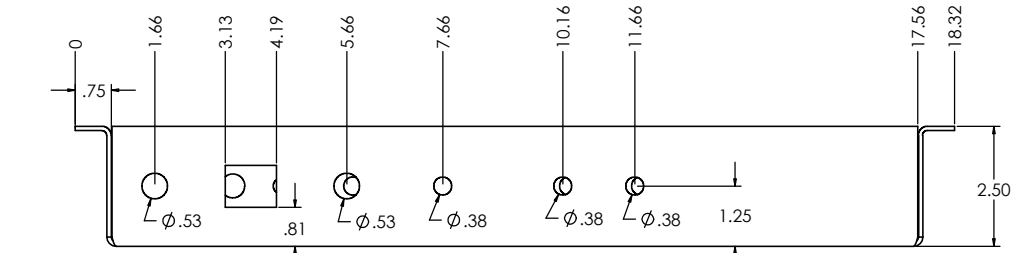
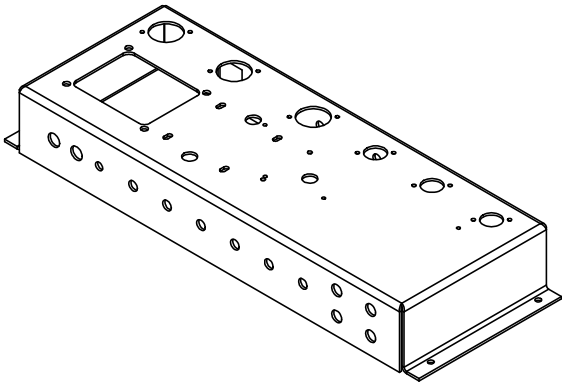

PROPRIETARY AND CONFIDENTIAL
 THE INFORMATION CONTAINED IN THIS DRAWING IS THE SOLE PROPERTY OF WeberVST. ANY REPRODUCTION IN PART OR AS A WHOLE WITHOUT THE WRITTEN PERMISSION OF WeberVST IS PROHIBITED.

		UNLESS OTHERWISE SPECIFIED:	NAME	DATE
		DIMENSIONS ARE IN INCHES	DRAWN	GA
		TOLERANCES:	CHECKED	5-9-05
		FRACTIONAL \pm	ENG APPR.	
		ANGULAR: ± 1	MFG APPR.	
		BEND $\pm .030$	Q.A.	
		TWO PLACE DECIMAL $\pm .015$	COMMENTS:	
		THREE PLACE DECIMAL $\pm .010$		
		INTERPRET GEOMETRIC TOLERANCING PER:		
		MATERIAL		
		.09 5052 ALM.		
NEXT ASSY	USED ON	FINISH		
		MILL		
APPLICATION		DO NOT SCALE DRAWING		

WeberVST		
TITLE:		
6M45CH-REVB		
SIZE	DWG. NO.	REV
E		B
SCALE: 1:1	WEIGHT:	SHEET 1 OF 1