

THIS FACE ON THE ASSEMBLED CHASSIS IS TO BE POLISHED TO A MIRROR FINISH BEFORE ASSEMBLY IS CHROME PLATED. FACE IS TO BE FREE OF SCRATCHES, SPOTTING, AND MISSOUTS.

REVISIONS		DATE	APPROVED
ZONE	REV.	DESCRIPTION	

TO BE ASSEMBLED WITH AN ENDCAP SPOT-WELDED FLUSH IN EACH END.

ASSEMBLED VIEW

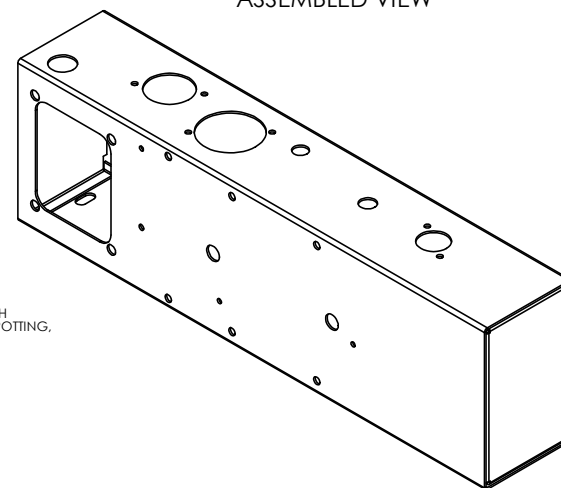

PROPRIETARY AND CONFIDENTIAL  
THE INFORMATION CONTAINED IN THIS DRAWING IS THE SOLE PROPERTY OF WeberVST. ANY REPRODUCTION IN PART OR AS A WHOLE WITHOUT THE WRITTEN PERMISSION OF WeberVST IS PROHIBITED.

		UNLESS OTHERWISE SPECIFIED:	NAME	DATE
		DIMENSIONS ARE IN INCHES	DRAWN	GA
		TOLERANCES:	CHECKED	2-11-06
		FRACTIONAL ±	ENG APPR.	
		ANGULAR: ±1	MFG APPR.	
		BEND ±.030	Q.A.	
		TWO PLACE DECIMAL ±.015	COMMENTS:	
		THREE PLACE DECIMAL ±.010		
		INTERPRET GEOMETRIC TOLERANCING PER:		
		MATERIAL 18 GA CRS		
NEXT ASSY	USED ON	FINISH CHROME		
APPLICATION		DO NOT SCALE DRAWING		

<b>WeberVST</b>		
TITLE:		
<b>5F2MAXCH-REVA</b>		
SIZE	DWG. NO.	REV
E		A
SCALE: 1:1	WEIGHT:	SHEET 1 OF 1